

# Vision Design Specifications

For Illustration Purposes Only - Not Drawn to Scale

## Track Latch System

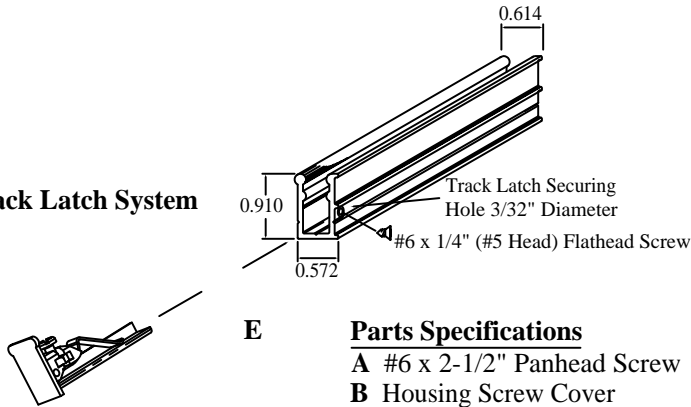

### Parts Specifications

- A #6 x 2-1/2" Panhead Screw
- B Housing Screw Cover
- C #6 x 3/4" Panhead Screw
- D Track Screw Hole Cover
- E Track Latch Assembly And Track

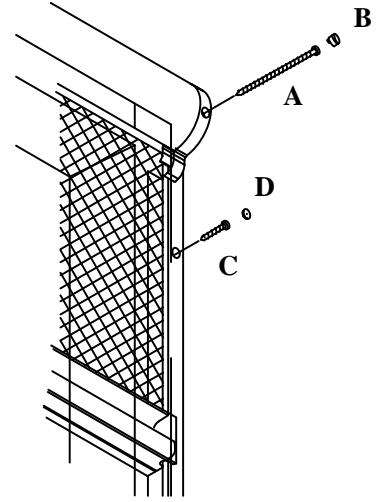

## Outside Frame (Surface) Mounting

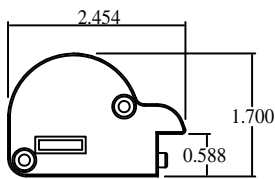

**Vision I  
Housing End Cap**  
Left Side View (External)

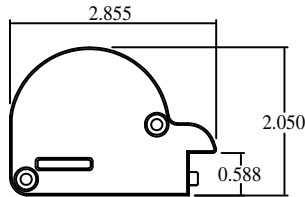

**Vision II  
Housing End Cap**  
Left Side View (External)

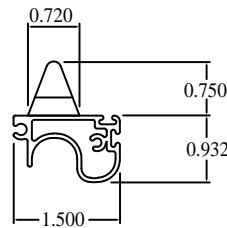

**Cross Section Through  
Slide Bar and Handle**

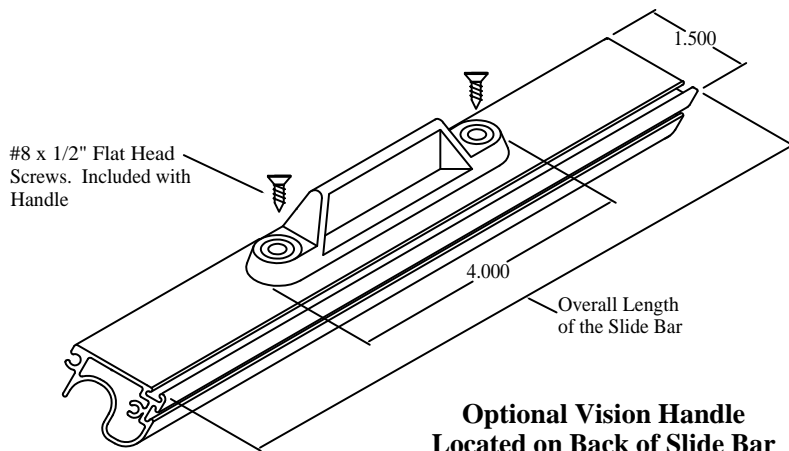

**Optional Vision Handle  
Located on Back of Slide Bar**

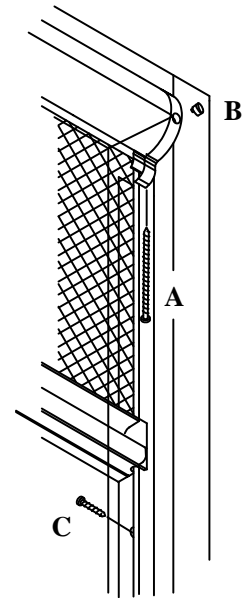

## Inside Frame Mounting