

Vision Design Specifications

(External Assembled View)

For Illustration Purposes Only - Not Drawn to Scale

Parts Spec

- A** Aluminum Track
5/8"w x 29/32"h
- B** Aluminum Slide Bar
1-1/2"w x 15/16"h
- C** Aluminum Housing
Vision I - 1-53/64"w x 1-23/32"h
Vision II - 2-15/64"w x 2-1/16"h
- D** PVC Coated Fiberglass Mesh
- E** #6 x 3/4" Panhead Screw
- F** #6 x Panhead Screw.
Lengths vary depending on
installation requirements.
- G** Track Screw Hole Cover
- H** Housing Screw Cover
- I** Track Latch Assembly (Adjustable)

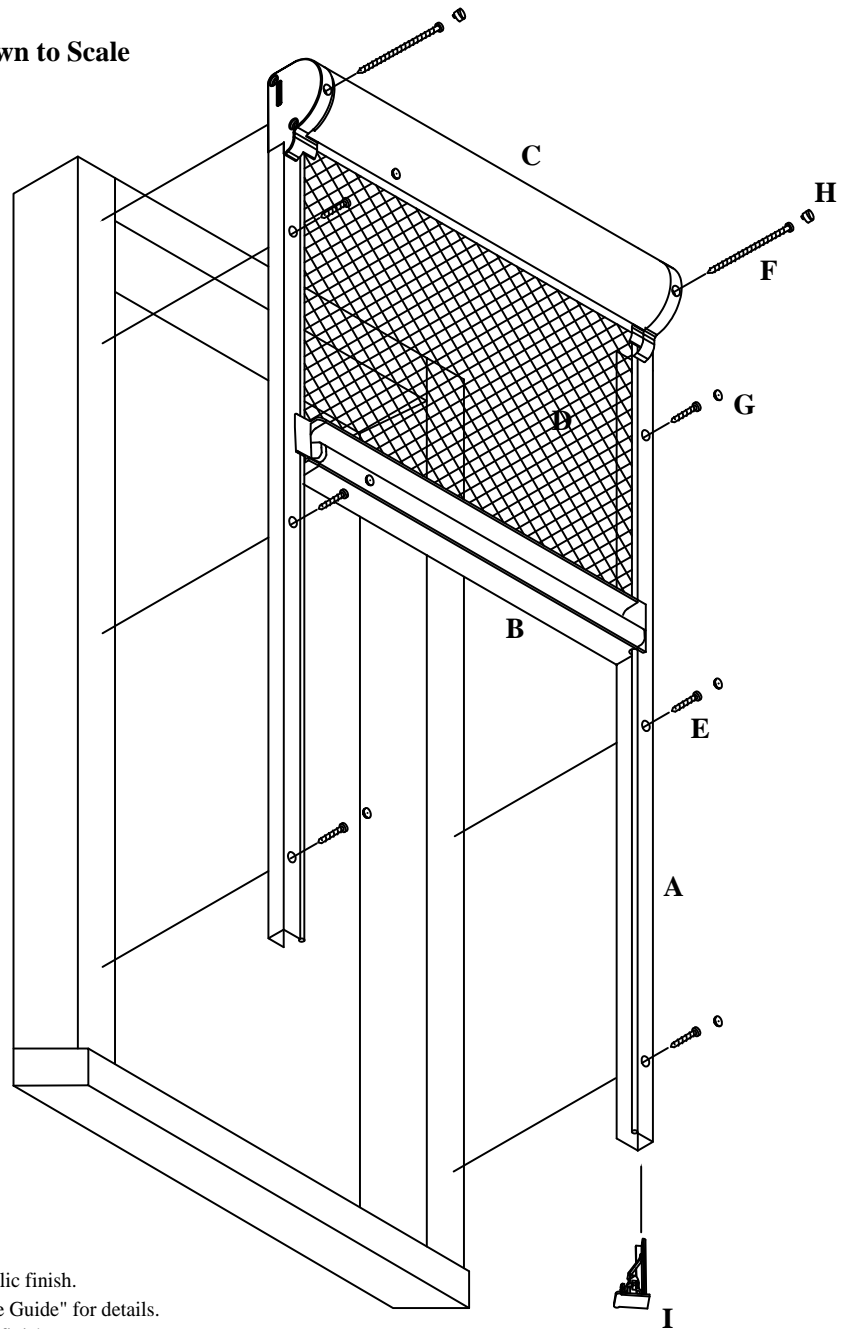

Aluminum components are extruded and have baked-on acrylic finish.
All fasteners are corrosion resistant. See "Fastener Reference Guide" for details.
Track and housing screw covers hide screw holes for a clean finish.
Housing screw covers follow the contour of the housing.