

# Phantom Door Design Specifications

## ( Detail Views )

For Illustration Purposes Only - Not Drawn to Scale

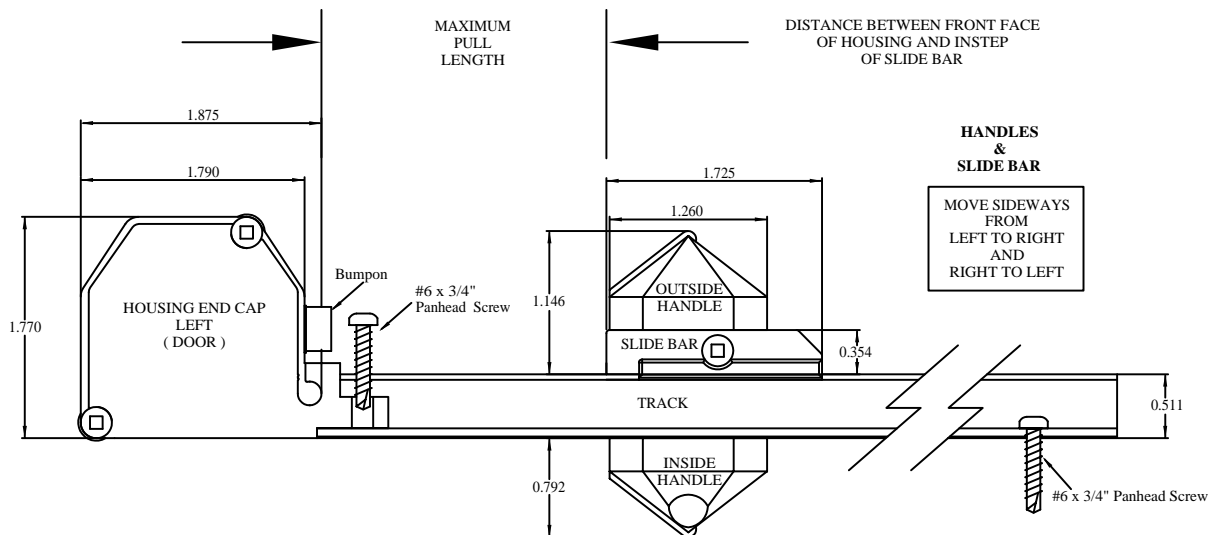

PLAN VIEW

### Parts Spec

- A Outside Nylon Handle
- B Inside Nylon Handle
- C Aluminum Slide Bar
- D #8 x 1-1/2" Panhead Screw
- E Corrosion Resistant Steel Magnet Strike Plate
- F #6 x 1/4" (#5 Head) Flathead Screw
- G Nylon Magnet Housing

### Parts Spec

- A Aluminum Housing c/w Nylon End Cap
- B Aluminum Track
- C #8 x 2-1/2" Flathead Screw
- D #6 x 3/4" Panhead Screw
- E Screws Position On Mounting Surface
- F Bumpons - 1/2" Ø x 1/4"H

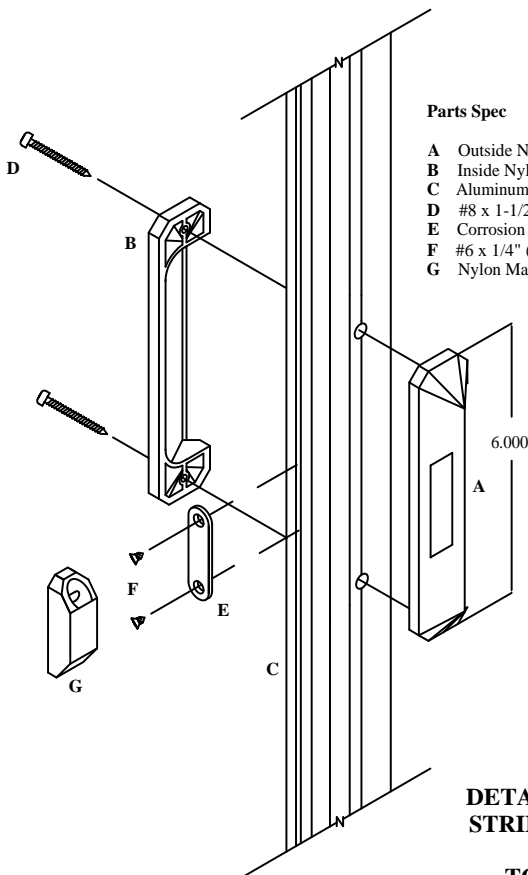

DETAIL OF HANDLE AND STRIKE PLATE POSITION IN RELATION TO THE SLIDE BAR

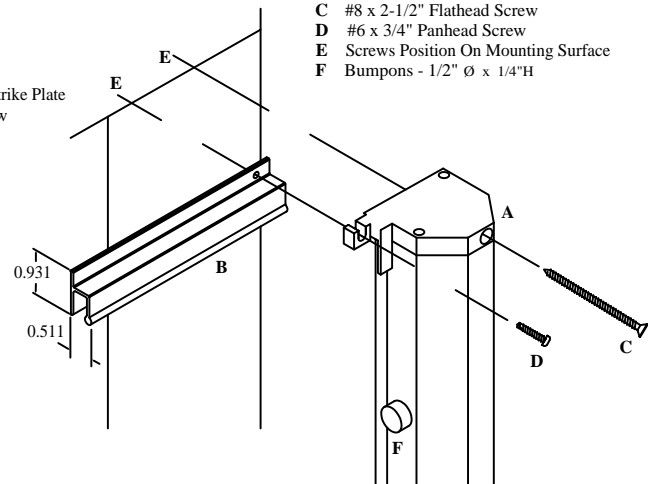

DETAIL OF TRACK POSITION IN RELATION TO THE HOUSING AND HOUSING END CAP ( HEAD VIEW )

All dimensions are in inches